



<http://www.adsequip.com/>

Installation Manual of Rear delivery unit with arm and table

Copyrights

ADS makes no warranty of any kind with regard to this material , including but not limited to, the implied warranties of merchantability and fitness for a particular purpose. ADS shall not be held liable for any errors contained herein or any consequential or other damages concerning furnishing, performance or use of this material. The information in this document is subject to change without notice . If you find any problems in the documentation, please report them to us in writing. ADS does not warrant that this document is error-free.

No part of this document may be copied, reproduced, altered, or transmitted in any form or by any means, electronic or mechanical, including photocopying, recording, or by any information storage and retrieval system, without prior written permission from ADS. The document is intended to be used in conjunction with the equipment.

Comments and feedback

Please contact us if you have any feedback and opinions on this document:

Add: 1590 S Milliken Ave., unit A, Ontario, CA 91761

Tel: (626) 620 0456

E-mail : sales@adsequip.com

<http://www.adsequip.com/>

Product service

If you want to get service information, please contact the local dealer authorized by ADS company.

Technical support tel: 800 488 9708

C O N T E N T S

1	Compositions.....	1
2	Sizes.....	2
3	Installation requirements.....	3
4	installation steps.....	4
5	Water and air connection.....	10
6	User's Manual.....	11
6.1	Functions introduction	12
6.2	Foot control.....	13
7	Cleaning, Disinfecting and Sterilization.....	15
7.1	Handpiece tubing cleaning & maintenance.....	15
7.2	Clean the filter.....	15
7.3	Troubleshooting.....	15
8.	Water diagrams	16

1 Compositions

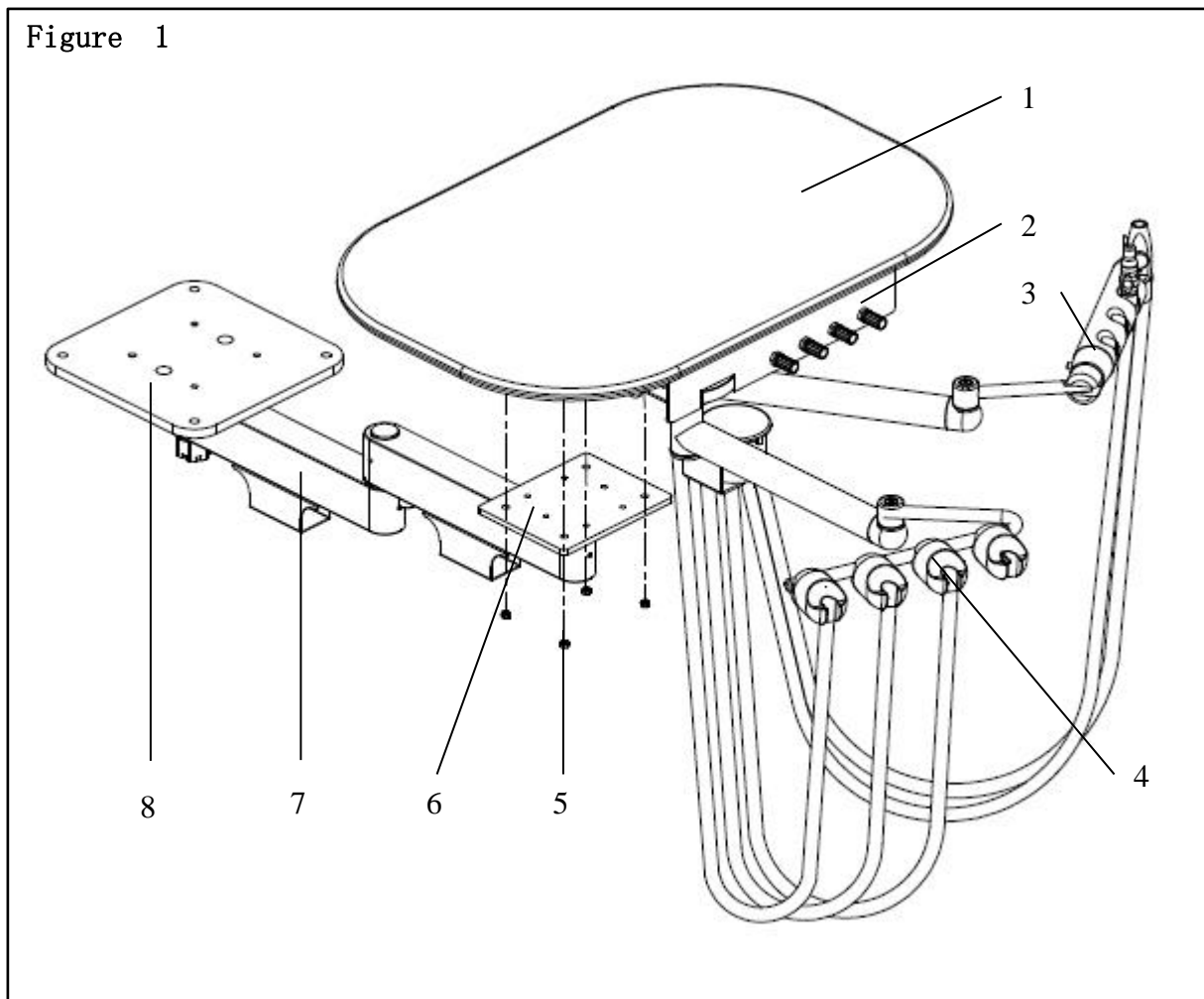

1	Work surface	5	Work surface Nut
2	Dentist's control	6	Work surface adapter
3	Assistant hanger	7	Under cabinet arm system
4	Handpiece hanger	8	Fixing plate

2 Sizes

Unit: inches

Figure 2

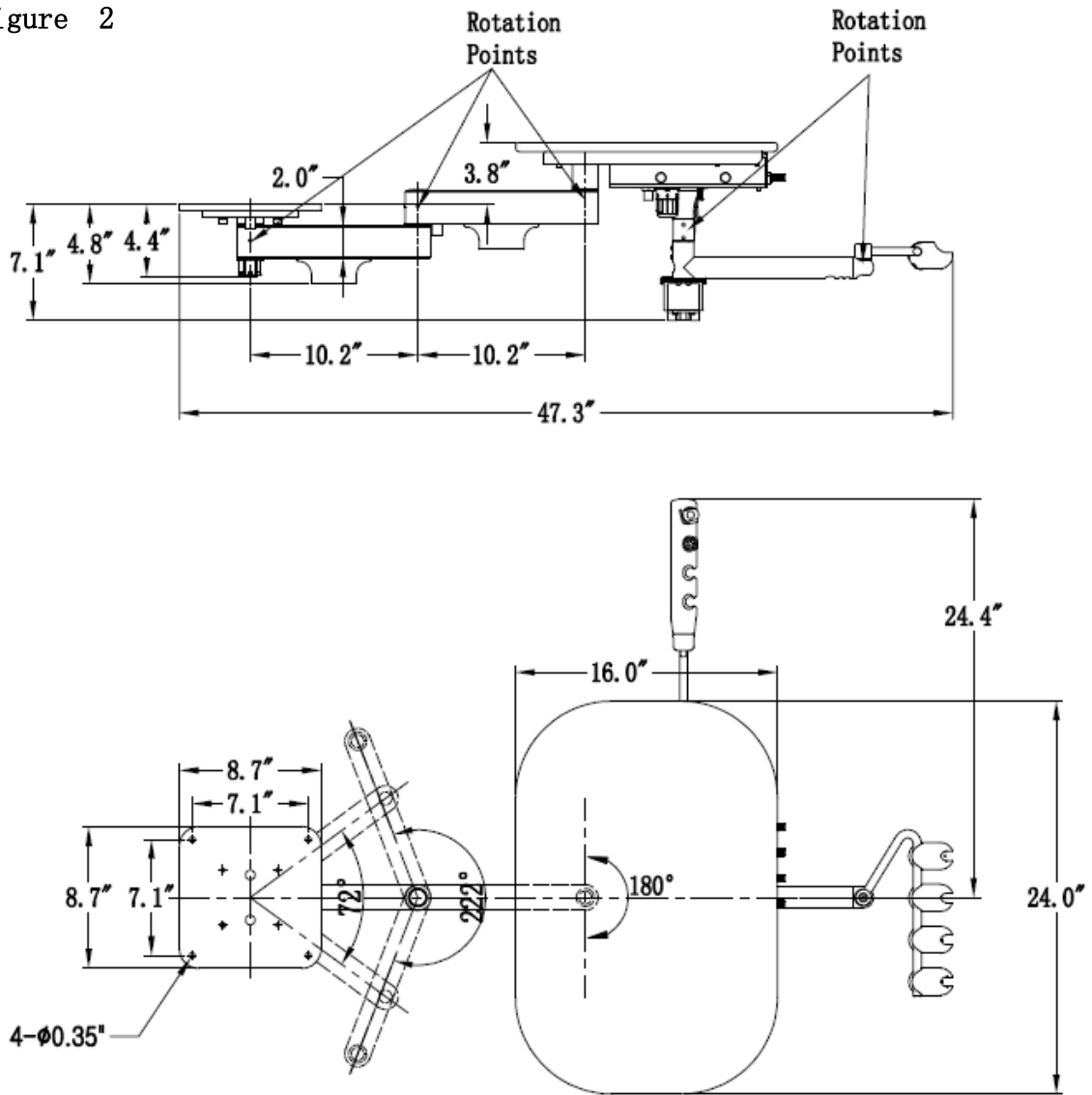

3 Installation requirements

This product is used in conjunction with a side cabinet (the size of the side cabinet below is for reference only).

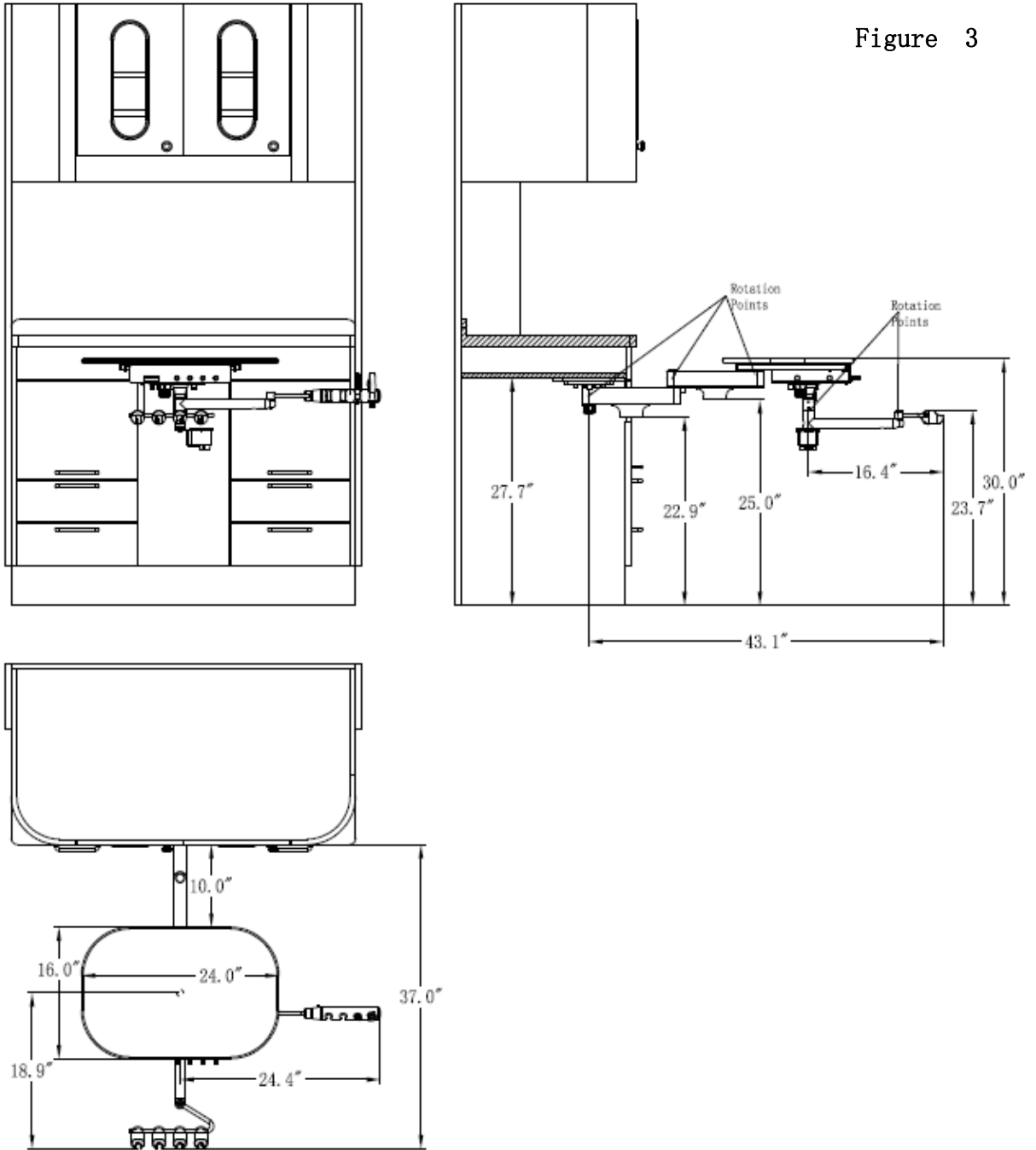
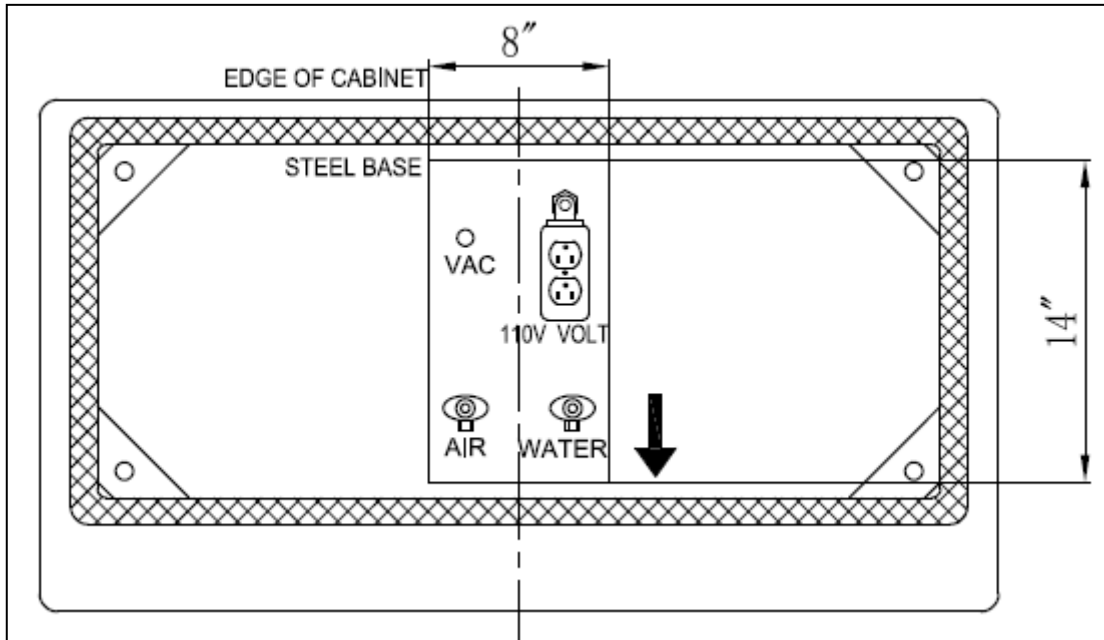

Figure 3

Installation Manual of Rear delivery unit with arm and table

The bottom of the cabinet needs to be reserved for water inlet, air intake, power supply, negative pressure suction pipe, etc. The range is determined according to the actual cabinet size. (The dimensions below are for reference only)

Figure 4



4 Installation steps

1. After the product is unpacked, pass the mounting shaft of the fixing plate through the shaft hole of the connecting arm, then put a flat washer to lock the slot nut, and finally insert a pin and tighten the nail screw.

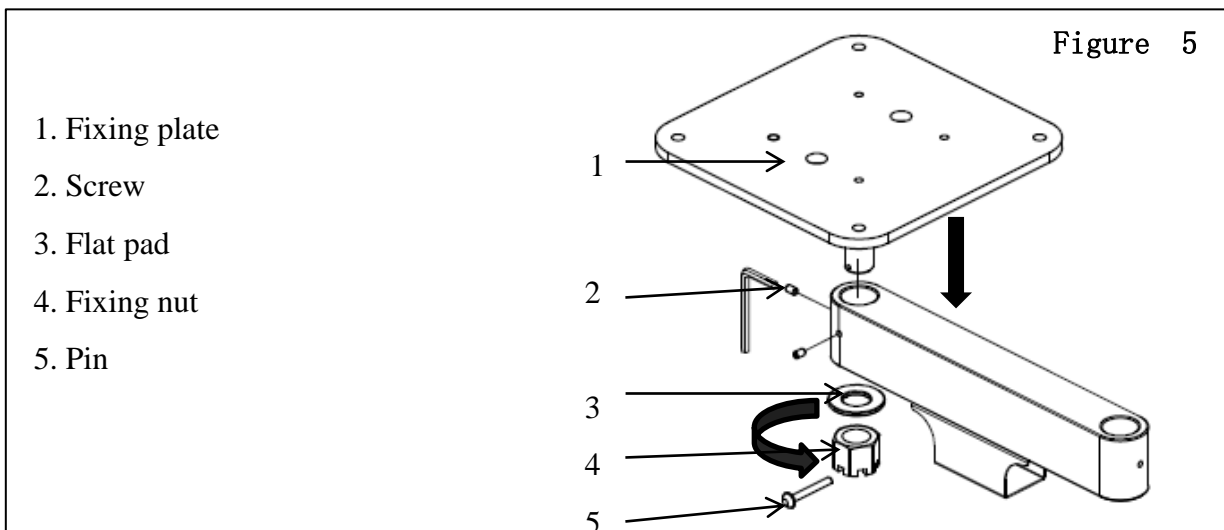

Installation Manual of Rear delivery unit with arm and table

2. Install the connecting arm assembly under the side counter. There are two ways of fixing:

Method 1: It is necessary to confirm that the thickness of the table used can bear the use of the product. After determining the installation position, punch a positioning hole on the bottom of the table and fix the fixing plate on the bottom of the table with self-tapping screws.

Method 2: After confirming the installation position on the table, drill 4 cylindrical countersinks and through holes, use bolts to pass through the table and the fixing plate, and then tighten with two nuts.

After installation, the level needs to be adjusted, which can be obtained by adjusting the set screws on the fixing plate.

Figure 6

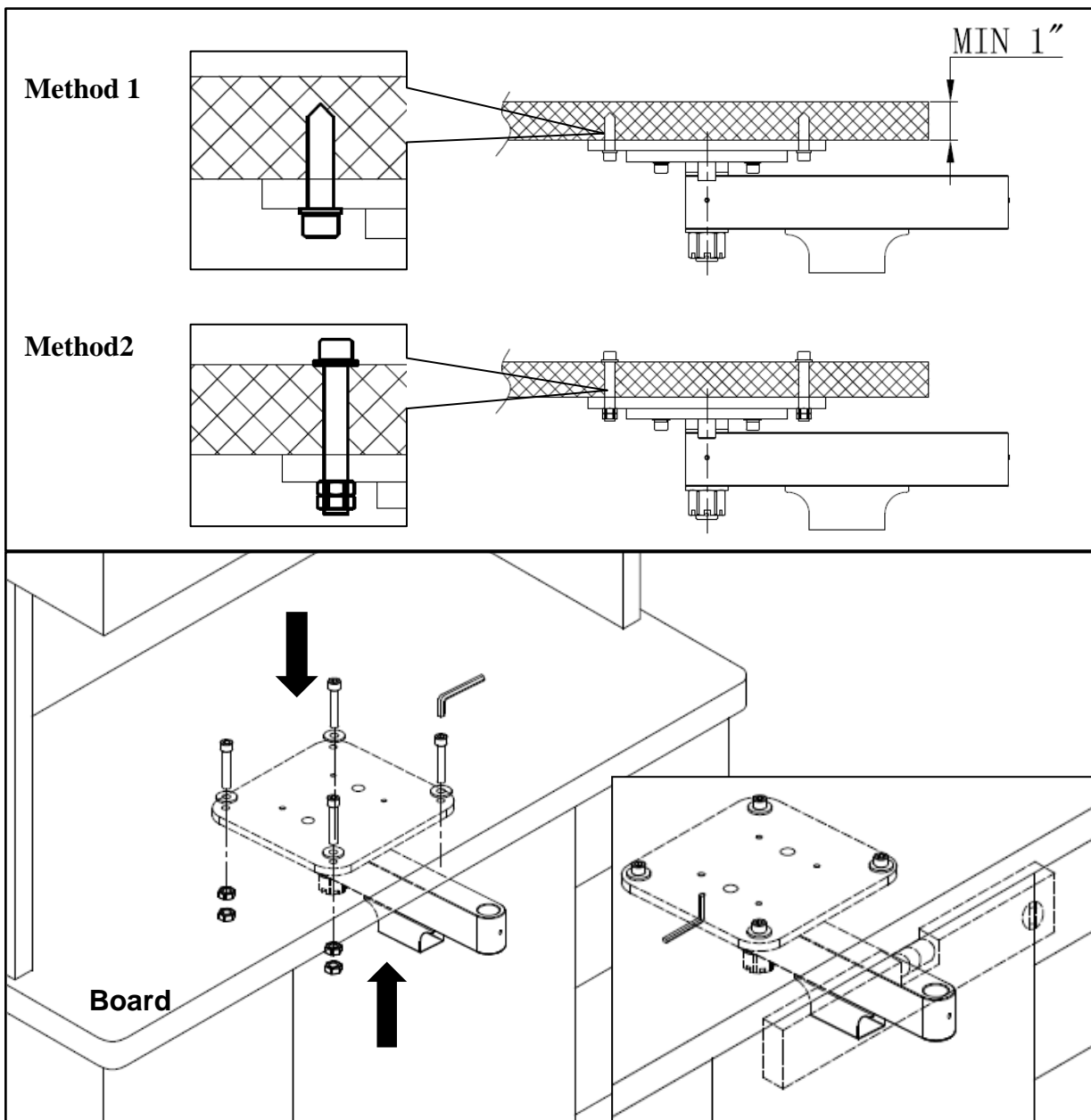

3. Insert the gasket of the mounting arm of the rotating arm into the hole of the connecting arm and lock the set screw.

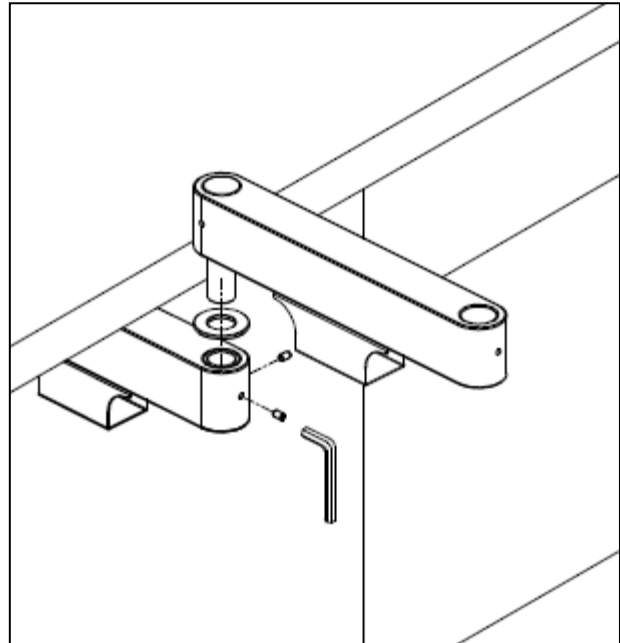

Figure 7

4. Place the work surface on the mounting plate, place the treatment system upside down, the mounting slot and the countertop mounting bolts on top, and then place the flat washer lock nut.

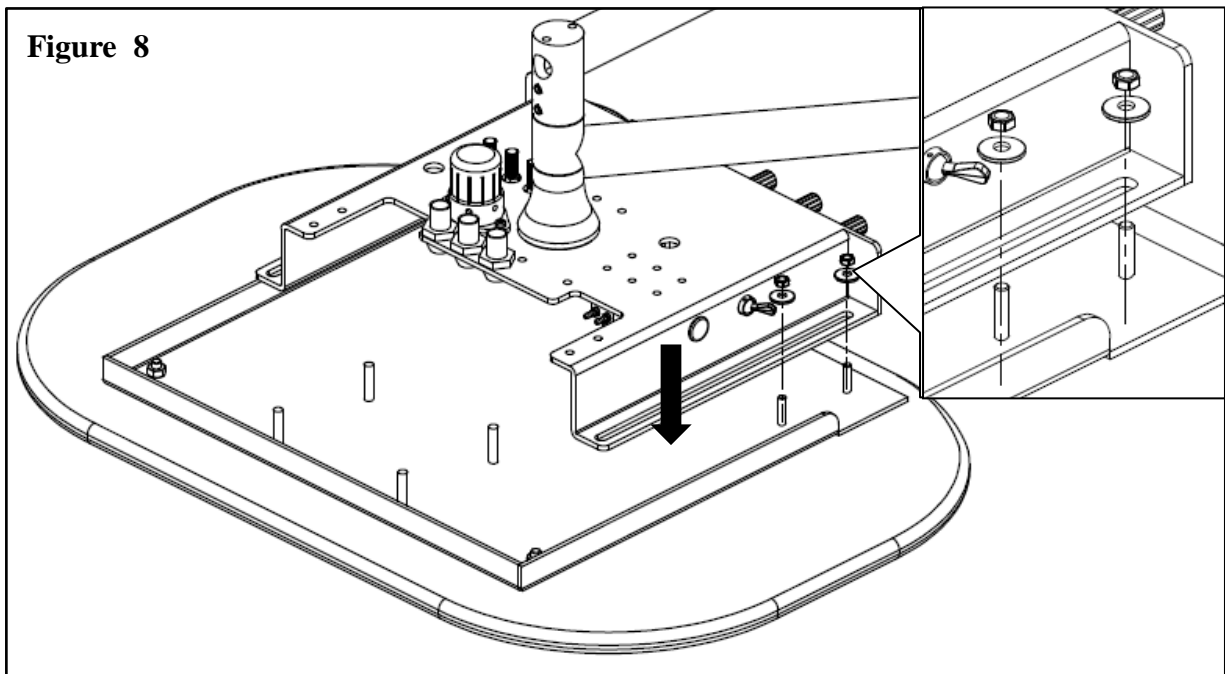
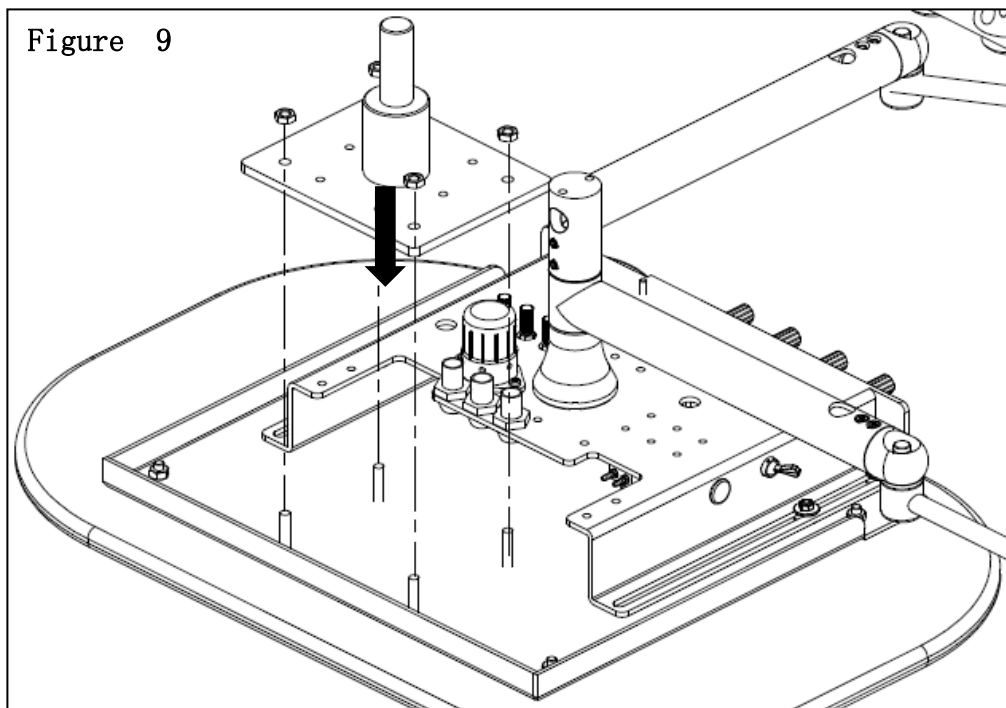

Figure 8

Installation Manual of Rear delivery unit with arm and table

5. Align the countertop connection plate with the mounting bolts on the countertop and lock the nut.



6. Turn the installed surface upside down, insert the installation shaft of the tabletop connection plate into the hole of the swing arm, and tighten the set screw.

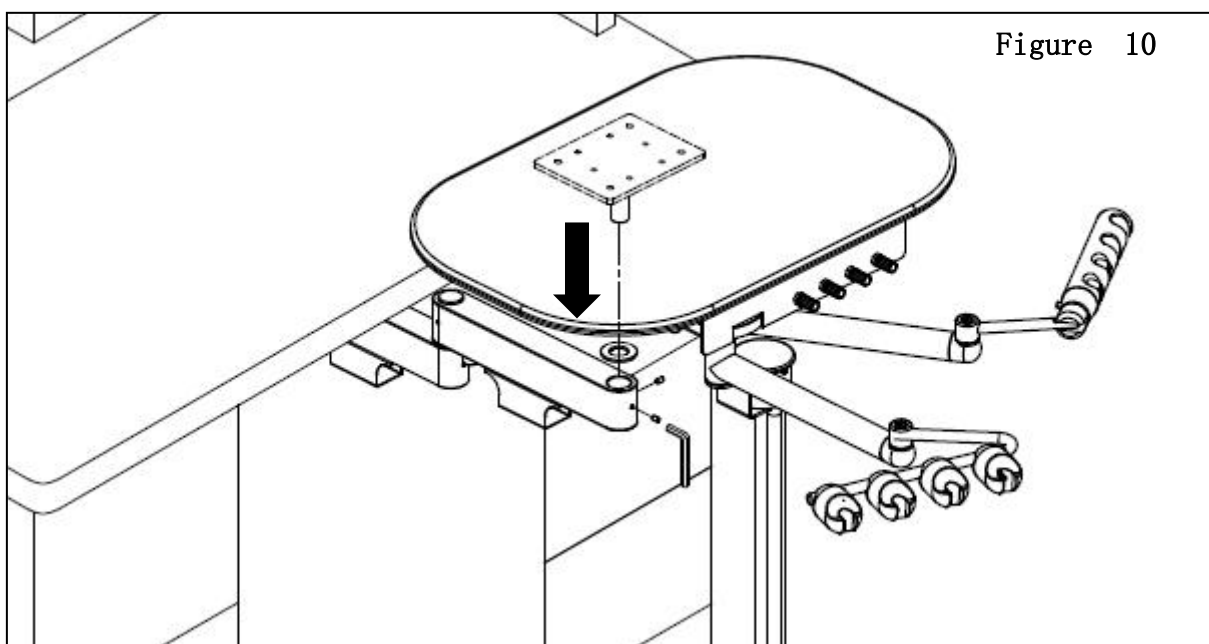

Installation Manual of Rear delivery unit with arm and table

7. Install the filter under the rotating shaft with two screws. Then hang the strong and weak suction handles on the assistant's hanger; the mobile phone tubes are respectively hung on the mobile phone hanger.

Figure 11

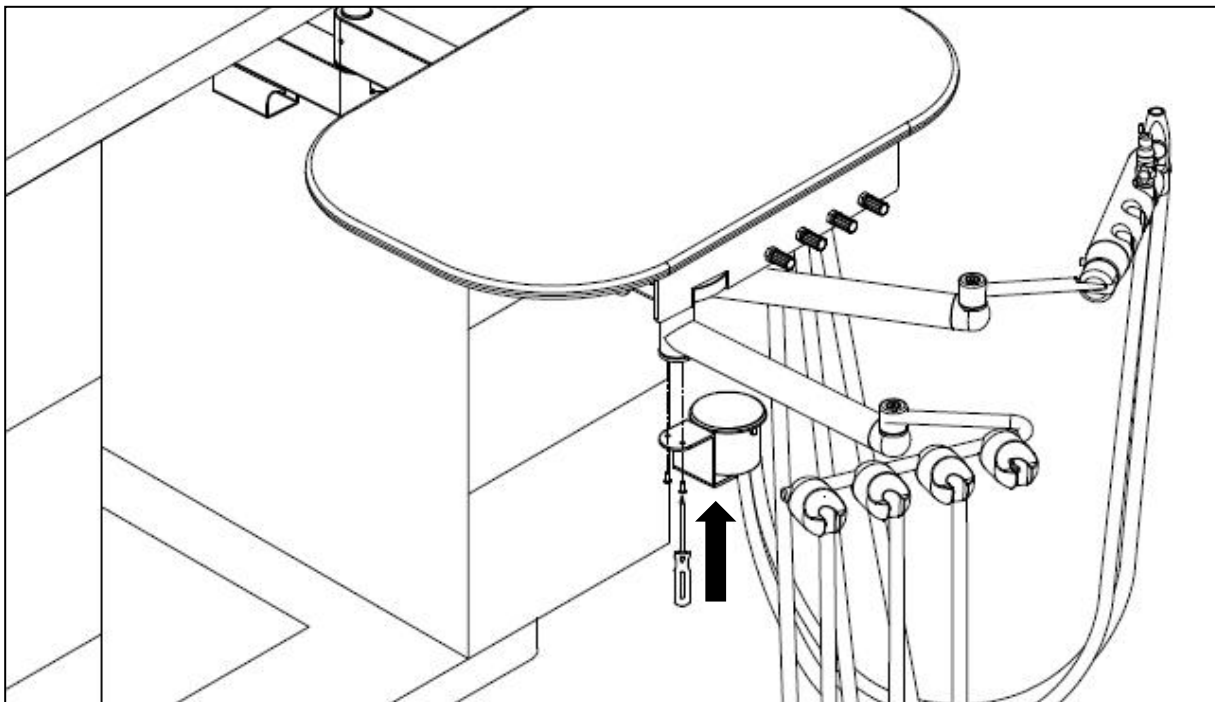

8. Rotate the water bottle to the bottom of the treatment system.

Figure 12

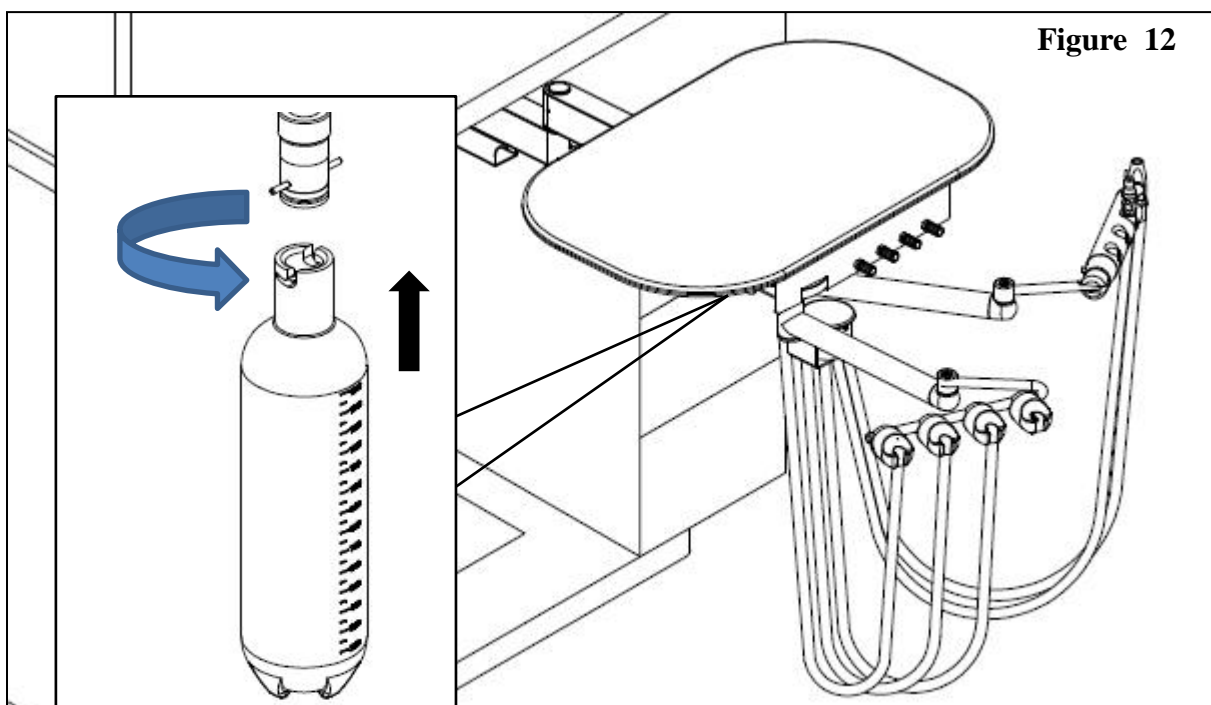

Installation Manual of Rear delivery unit with arm and table

9. To adjust the level of the work surface, you can get the level by adjusting the 4 set screws of the table connection board.

Figure 13

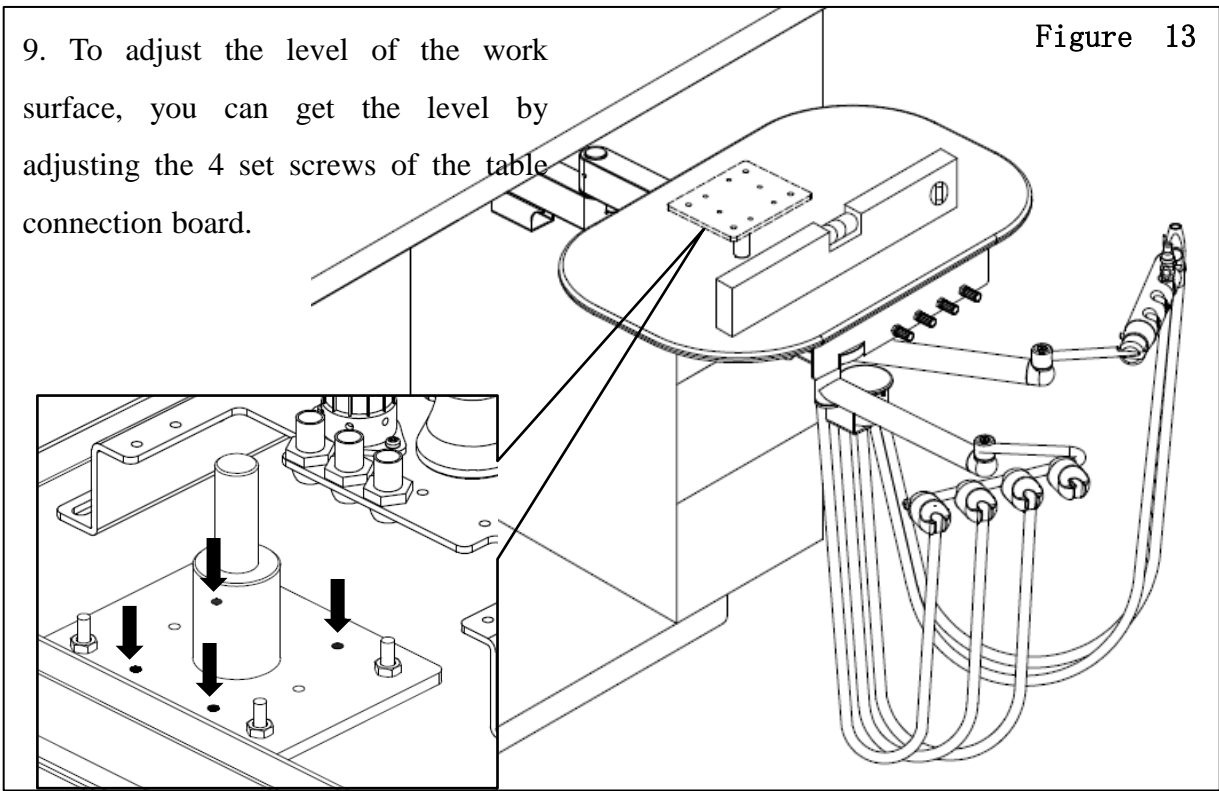

10. Connect the corrugated line bundle of the treatment system through the swing arm to the cabinet bottom valve body.

Figure 14

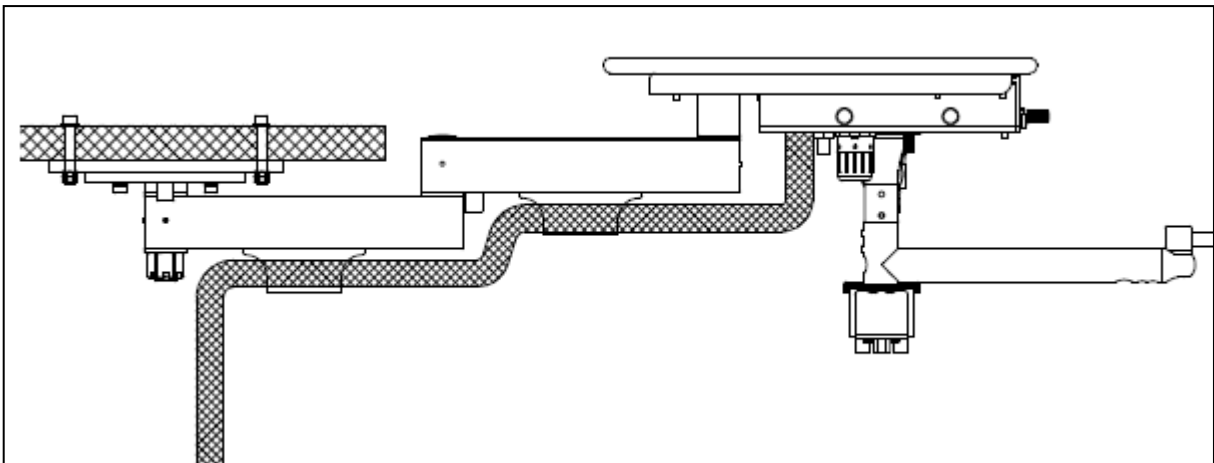

11. Connect the pipeline to the valve body according to the color, and finally connect the water and air negative pressure nozzles reserved at the bottom of the cabinet.

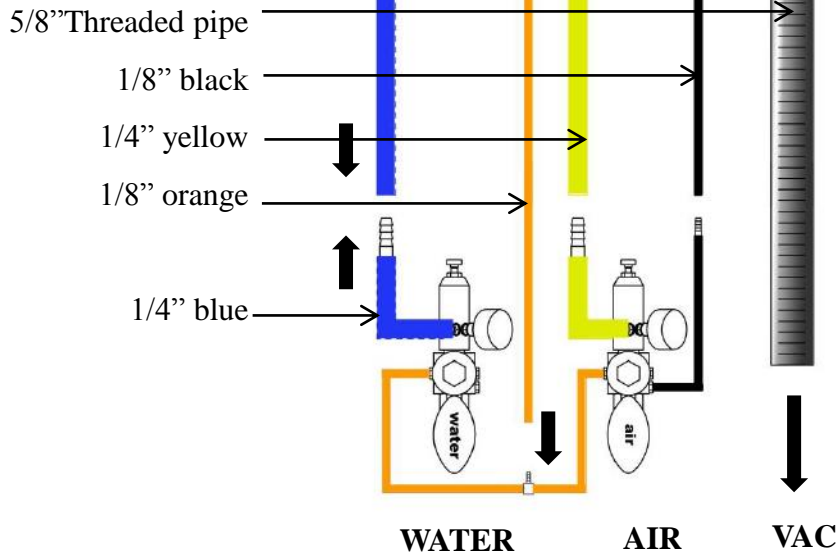

Figure 15

5 Water & Air connection

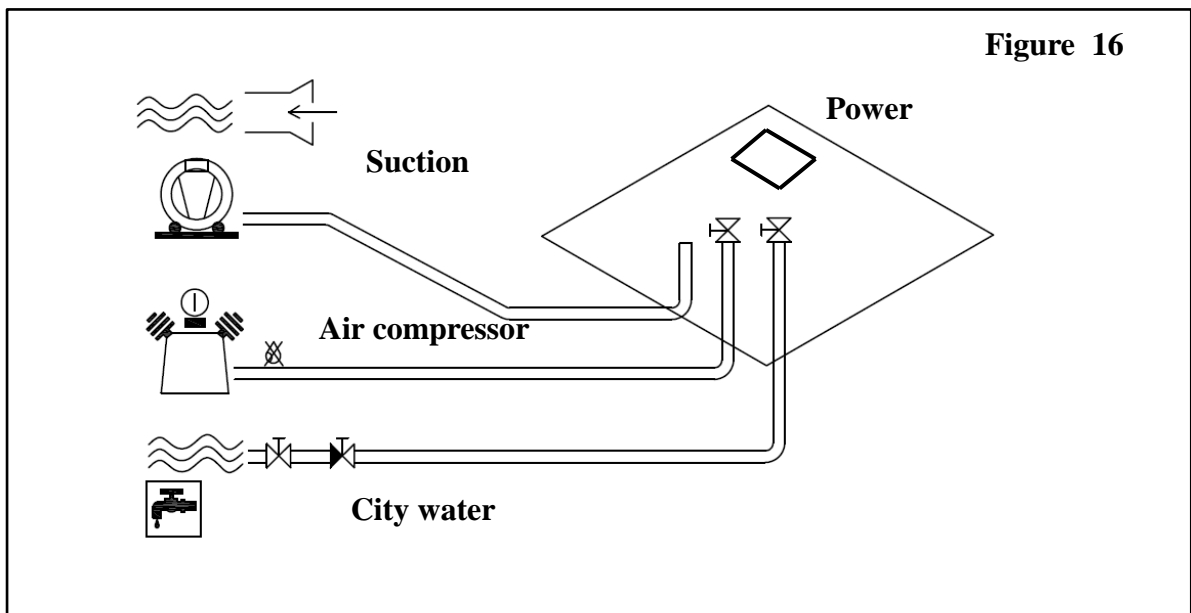
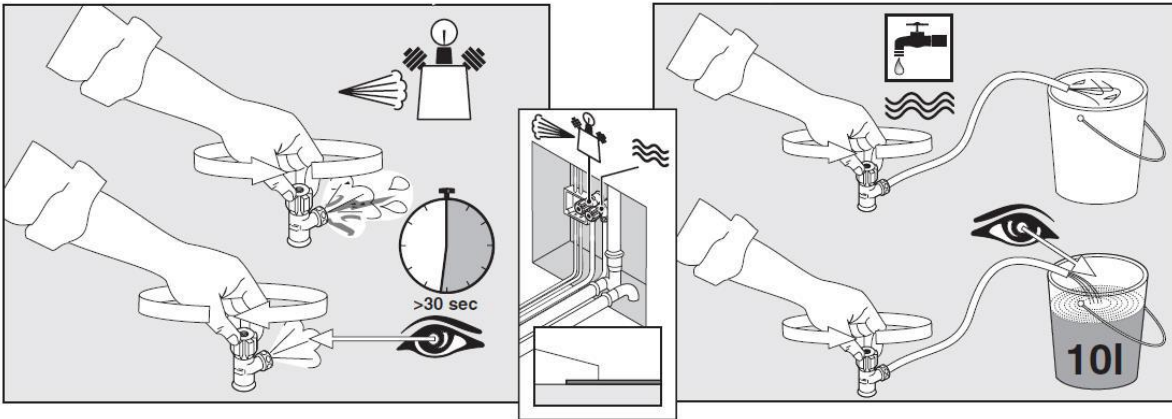

Figure 16

Figure 17



The tubes & wires are in the tubing zone or inside the external junction box, their places depend on your chair configurations.

1. Open the valves to exhaust water and air, clean the tubes before connecting.
2. Open the cover of the junction box, connect the air-in, water-in and water-out .
3. Take out the power box of dental light ,connect the power cord to the power box, and plug into the socket.
4. Close the cover after making sure they are well-performed.

6 User's Manual

Figure 18

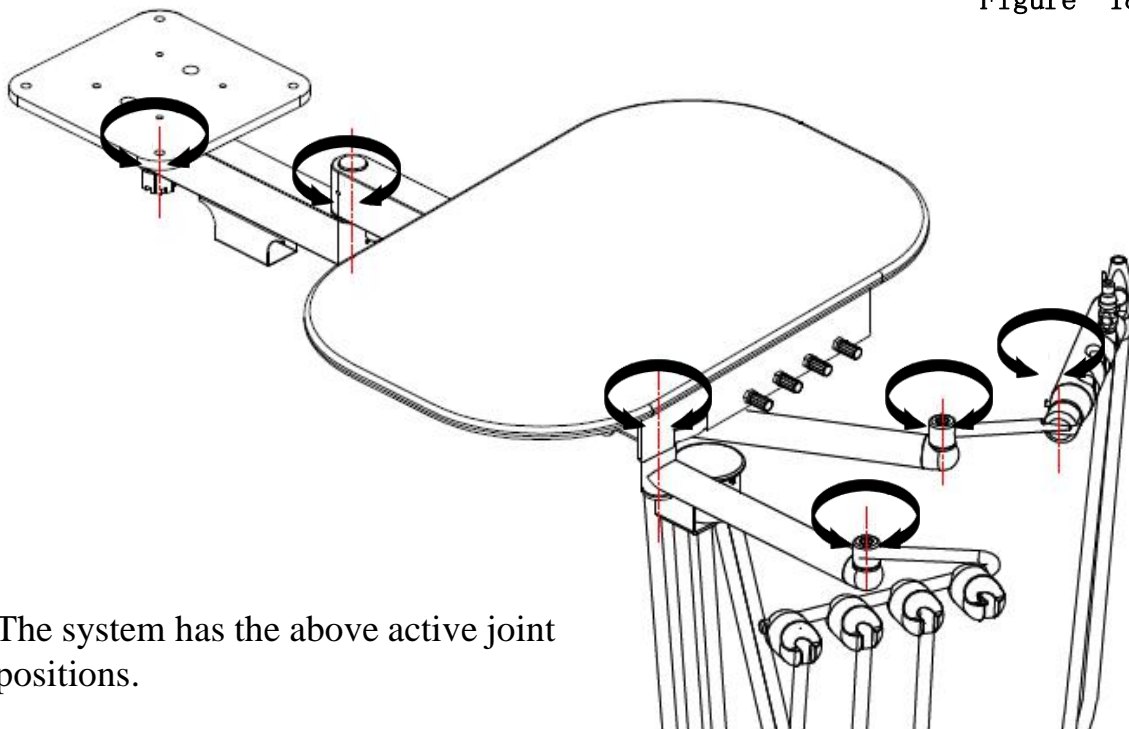

The system has the above active joint positions.

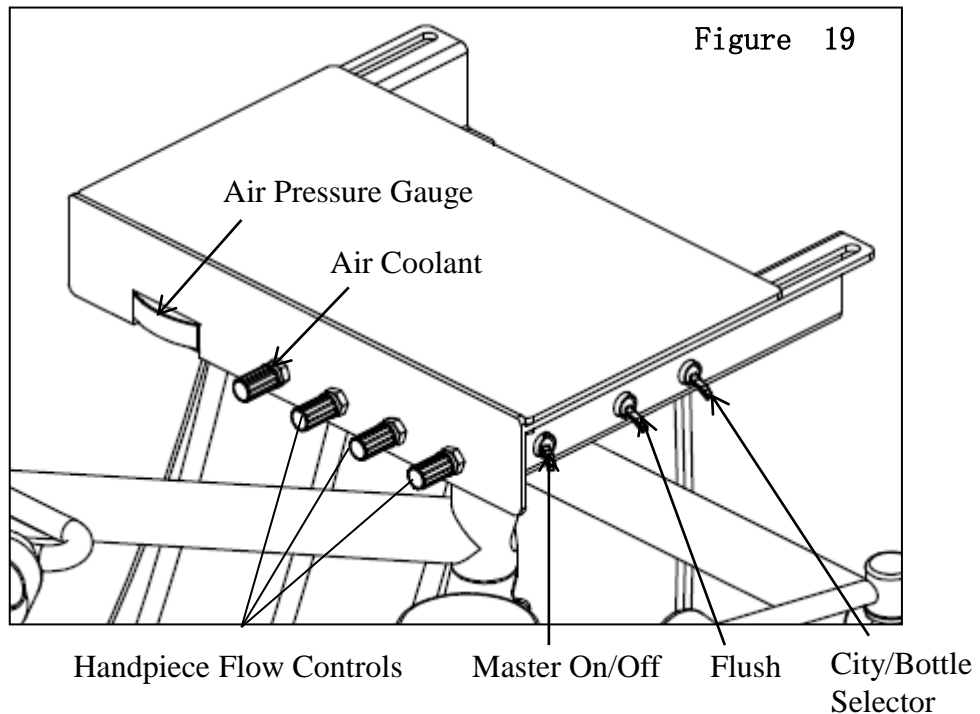

6.1 Functions introduction

Master On/Off: This toggle switch activates the air & water shut-off valves, which control the air and water supplies to the unit.

Air Coolant : This master control valve adjusts the amount of air coolant flow to all of the handpieces. Rotate in counterclockwise to increase flow, clockwise to decrease flow.

Handpiece Flow Controls: These individual control valves adjust the amount of water coolant supplied to its corresponding handpiece. Rotate the control valve counterclockwise to increase water coolant, clockwise to decrease water coolant.

Flush: This toggle is used to purge the coolant water from the handpiece tubing. Hold the handpiece tubing over a suitable container, then activate and hold the toggle for at least 30 seconds to flush out the handpieces.

City/Bottle Selector: This routing valve controls the water system input. With the toggle up in the “City” position, water enters the dental unit from the office plumbing. With the toggle down in the ”Bottle” position, water enters the dental unit from self-contained water system.



CAUTION: Only water bottles supplied by the manufacturer can be used .Do not use soft drink bottles which are thin walled and may rupture when under pressure.



CAUTION: Avoid operating the handpieces for extended periods longer than is required to check gauge pressure.Extended operation without load can damage the handpiece.Do not operate the handpiece without a burr in the chuck.

6.2 Foot control

Delivery system is equipped with wet-dry, variable speed, disc type foot controls. Foot pressure on any part of the disc controls the flow of air to the active handpiece.

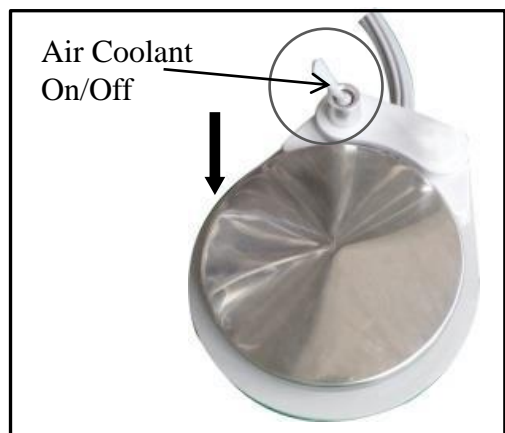
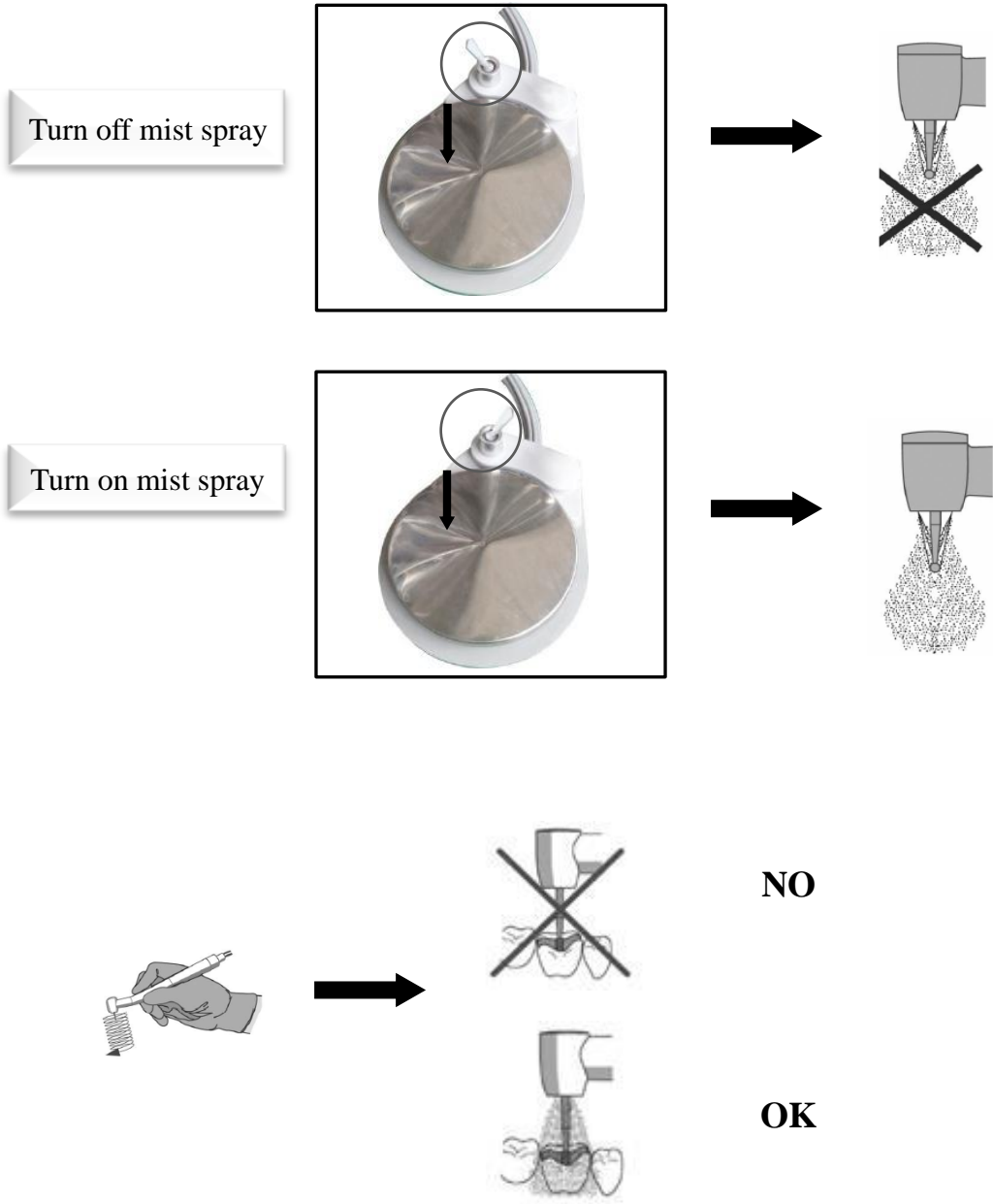

Figure 20

Water Coolant On/Off: This toggle interrupts the flow of water coolant to the handpieces when performing a procedure that requires dry cutting.

Figure 21 Handpiece adjustment:



Hint : Adjust the drive air pressure to meet the demands of handpiece manufacturer's drive air pressure specifications. Refer to your handpiece documentation for the drive air pressure specification.

7 Cleaning, Disinfecting and Sterilization

7.1 Handpiece tubing cleaning & maintenance

Flush the tubings independently or together, After each patient:

1. Disconnect the handpiece before flushing the conduit.
2. Gather handpiece tubings that use water coolant and hold them over a sink, cuspidor bowl, or basin.
3. Hold the tubings so that the water is directed away from you and into the receptacle .
4. Flush the tubing continuously about 20~30 min.

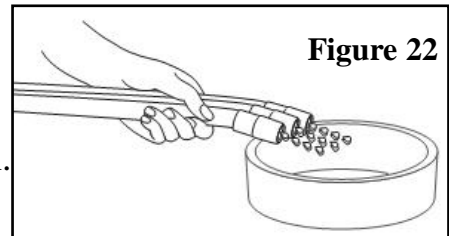

Attention: After each patient, air and water of all the tubes is to be released around 20-30 seconds, to reduce cross infection and potential bacterial contamination.

7.2 Clean the filter

The filter aids in preventing solids from entering the suction system . To ensure a good working state of the suction system, please clean the filter screen at least twice a week.

To clean the filter:

1. Close the suction system.
2. Pull out the filter ,remove the filter screen and clean the solids.
3. Reinstall the filter.

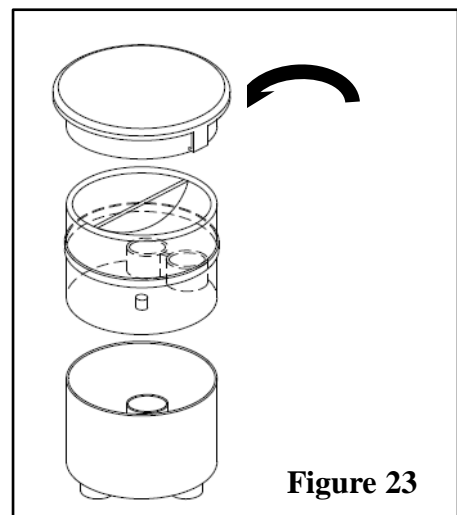

7.3 Troubleshooting

Please contact your local dealer for help if there is malfunction occurred in your system.

8. Water diagrams

Figure 24

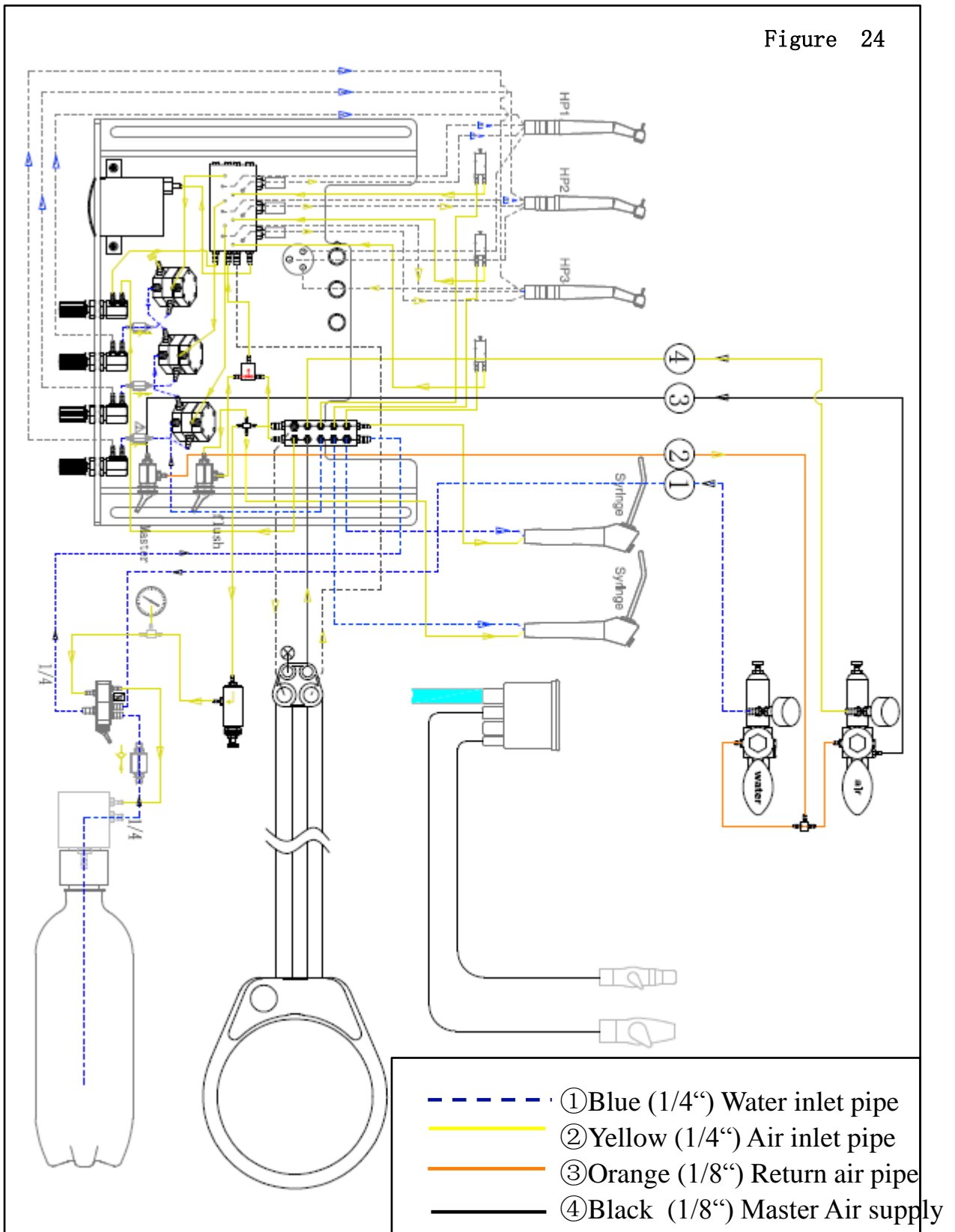

We reserve the right to make any alterations which may be due to technical improvements.



710422

ADS Dental System Inc.

Add: 1590 S Milliken Ave., unit A, Ontario, CA 91761

Tel: (626) 620 0456

E-mail: ads@adsequip.com

<http://www.adsequip.com/>